

The Lab 004

Operating Manual

Premise

This operating manual contains important information on the functions of The Lab 004.

This operating manual is issued by ARKRAY, Inc. Read carefully prior to starting up the unit. It is recommended to retain this operating manual for future use.

This product conforms to the EMC Standard IEC61326-2-6:2012 (EN61326-2-6:2013).
Class of emission: CISPR 11 Class A
This instrument is an IVD medical instrument.



This product conforms to European Directive 98/79/EC.

NOTE: This instrument generates, uses and can radiate radio frequency energy and, if not installed and used in accordance with the operating manual, may cause harmful interference to radio communications. Operation of this instrument in a residential area is likely to cause harmful interference in which case the user will be required to correct the interference at his own expense.

The electromagnetic environment should be evaluated prior to operation of the device. Do not use this device in close proximity to sources of strong electromagnetic radiation, as these may interfere with proper operation.

Introduction

Thank you for purchasing our compact biochemical analyzer, The Lab 004. Read this operating manual thoroughly before using the instrument. This operating manual gives an overview of the instrument and the proper procedures for operation and maintenance. Follow the instructions in this operating manual in order not to defeat the purpose of the protective features of the instrument. For the purchase of reagents, consumables or other optional items, contact your distributor.



- **TAKE THE UTMOST CARE WHEN HANDLING BLOOD.** This instrument uses blood as sample. Blood may be contaminated with pathogenic microorganisms that can cause infectious diseases. Improper handling of blood may cause infection to the user or other individuals by pathogenic microorganisms.
- This instrument is to be operated by qualified persons only. A qualified person is one having adequate knowledge of clinical testing and the disposal of infectious waste. Thoroughly read this operating manual before use. Anyone who operates the instrument for the first time must be assisted by a trained person.
- Never touch the strip tray or other parts where the sample may adhere with your bare hands. During cleaning or maintenance of these parts, wear disposable gloves to prevent exposure to pathogenic microorganisms.
- Dispose of used samples, tips, test strips, parts and instrument in accordance with local regulations for biohazardous waste.

NOTE:

This product is a precision instrument. Handle the instrument with care. Do not subject the instrument to strong impact or vibration

- It is strictly prohibited to copy any part of this operating manual without the expressed consent of ARKRAY, Inc.
- The information in this operating manual is subject to change without notice.
- ARKRAY, Inc. has made every effort to prepare this operating manual. Should you discover anything strange, incorrect or missing, please contact your distributor.

Symbols

The following symbols are used in this operating manual to call your attention to specific items.

■ **For your safety**



Follow the instructions given here to prevent exposure to pathogenic microorganisms.



Follow the instructions given here to prevent injury and property damage.

■ **For optimal performance**

IMPORTANT:

Follow the instructions given here to obtain accurate measurement results.

NOTE:

Information useful for preventing damage to the instrument or parts, and other important information you should keep in mind.

REFERENCE:

Additional explanations that help you make the best use of the instrument and information on related functions.

Caution Labels

This instrument has a caution label on an area that poses a potential danger. Please learn about the danger warned of by this label and observe the precaution described below.

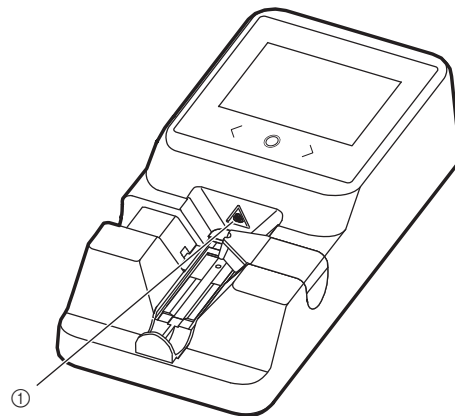

① **Strip tray**



Do not touch the strip tray with your bare hands. Wear disposable gloves to prevent exposure to pathogenic microorganisms while setting the test strips or cleaning the strip tray.

Chapter 1 Before Use

1.1 Overview

1.1.1 Features

■ Compact size enables installation in almost any location

This compact instrument is close to A5 in size, and weighs less than 1 kg for easy carrying. Water supply and drainage equipment is not needed, so the instrument can be easily installed in any location and used for immediate testing during physical examinations and in clinics. This instrument can be used to measure multiple biochemical items that are useful for monitoring internal disease and other conditions, such as creatinine.

■ Easy calibration by IC-CHIP

Calibration can be performed without the need for a calibrator using the IC-CHIP provided with each test strip. When opening a reagent, simply read the IC-CHIP into the instrument. This enables automatic calibration, even for differences between lots.

■ Identification of reagent type by barcode

When measurement is started the type of reagent loaded is automatically identified. Multiple reagent types can be measured without the need for additional operation.

1.1.2 Specifications

Name	The Lab 004
Configuration	Instrument, accessories
Measurement objects	Plasma or serum
Supported test strips	The Lab 004 test strips
Measurement items	Listed in package insert of reagent
Measurement ranges	Listed in package insert of reagent
Measurement principle	Dual-wavelength transmitted light measurement
Number of test strips measurable at once	1
Measurement time	Listed in package insert of reagent
Sample consumption	Listed in package insert of reagent
Required sample volume	Approximately 4 µL
Number of measurement samples	1 sample
Startup time	Approximately 10 minutes (in environments 25°C and below)
Memory capacity	50 measurements
Display	Segment LCD
Operation buttons	Flat keypad
External output	Micro USB type B
Measurement environment	Temperature: 10 - 35°C Humidity: 20 - 80% RH (No condensation)
Storage environment	Temperature: 1 - 35°C Humidity: 20 - 80% RH (No condensation)
Environment during transport	Temperature: -10 - 60°C Humidity: 20 - 80% RH (No condensation)
Dimensions	110 (W) × 225 (D) × 54 (H) mm
Weight	Approximately 1 kg
Power requirements	100 - 240 V AC, 50/60 Hz (with AC adapter)
Power consumption	Maximum 33 VA
AC adapter	5 V DC
Sound pressure level	Less than 80 dB
Location of use	For indoor use only
Altitude	Up to 2000 m
Pollution degree	2
Over voltage category	II
Temporary over voltage	Short-term: 1440 V Long-term: 490 V
Expected life	5 years (According to company data)

1.1.3 Measurement Principle

■ Test strip measurement

The instrument is equipped with multiple light source LEDs of varying wavelength. The light is dispersed on the light path and transmitted to the photometric unit. The dispensed sample fills the photometric cell and reacts with the reagents in the cell, changing the absorbance and turbidity. The light source LED shines on the cell, and the light that transmits through is read by a photodiode (receiver). The amount of transmitted light that is read is converted to a concentration.

1.2 Unpacking

Unpack the box and make sure you have all items listed in this section. If anything is missing or damaged, contact your distributor.

- Instrument
- Power cord
- AC adapter
- Operating manual
- Pipette

1.3 Part Names and Functions

1.3.1 Front View

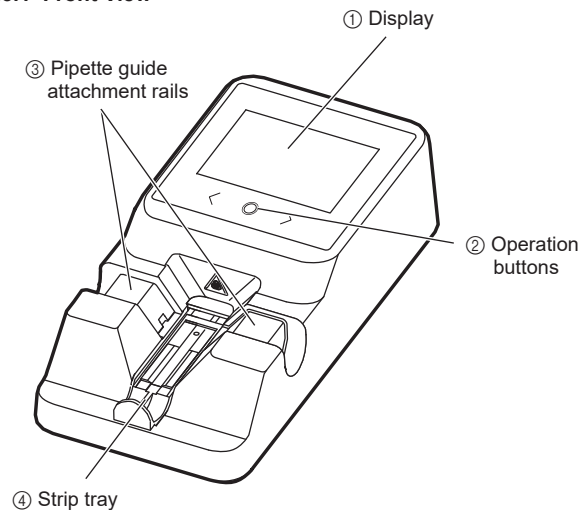

1.3.2 Rear

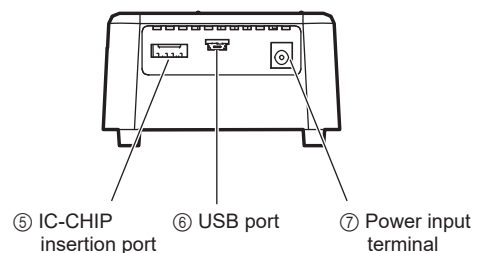

1.4 Installation

1.4.1 Precautions for Instrument Installation

Before installation of the instrument, read the following notes and always take proper safety precautions.

- Determine a location for the instrument and install it in that location. Hold the bottom of the instrument with both hands when carrying it.
- Install the instrument on a surface with sufficient clearance around the instrument. Do not block the vents on the back of the instrument.
- Install the instrument where temperature and humidity can be maintained in the following ranges:
Temperature: 10 - 35°C
Humidity: 20 - 80%
Installation in an environment outside these ranges may cause inaccurate measurement results.
- Install the instrument on a level, sturdy, vibration-free platform. Operation of the instrument in an unstable place may cause trouble with or malfunction of the instrument resulting in personal injury. Do not install the instrument where it may fall off or topple over.
- Do not use the instrument in a location where dust has accumulated. There is a risk of current leakage.
- Do not install the instrument near:
 - Places that store chemicals
 - Equipment that generates corrosive gas or electrical noise or
 - Equipment that may bring the instrument out of the operating temperature and humidity ranges.

These factors may cause trouble with or malfunction of the instrument, resulting in personal injury, or may otherwise cause inaccurate measurement results.

- Install the instrument in a place where condensation, intense light such as direct sunlight or wind can be avoided. These factors may cause inaccurate measurement results, as well as deformation of or damage to the instrument.
- Apply the correct voltage (100 - 240 V AC \pm 10%) and frequency (50/60 Hz) to the instrument. Improper voltage and frequency may result in fire or damage to the instrument and consequently lead to personal injury.
- Use the power cord and AC adapter that come with the instrument.
- Connect the AC adapter directly to a single outlet. The power supply for the instrument is 33 VA. If you use a power strip, make sure it is grounded. Also, check if the power capacity for the power strip is within the specified range.
- It is possible to use a commercially available mobile battery in place of the provided AC adapter. Use a battery with a rating of 5 V and 2.0 - 2.4 A.
- Do not disassemble the instrument. Do not modify the instrument. Disassembly and modification of the instrument may result in exposure to pathogenic microorganisms or cause fire or damage to the instrument and consequently lead to personal injury.

1.4.2 Precautions for Instrument Relocation

Before relocating the instrument, read the following notes and always take proper safety precautions.

- Hold down the \odot button to turn off the power, and then disconnect the power cable from the instrument.
- Remove the test strip from inside the instrument. There is a risk of pathogenic microbes scattering inside the instrument if the instrument is moved with a test strip still inside.
- If the instrument will be moved a long distance, secure the strip tray and pipette guide with tape to ensure that neither opens or comes off.

- There is a risk of instrument failure if moved without securing the strip tray and pipette guide. Place the instrument in the dedicated box together with the accessories to move.
- Do not subject the instrument to shock or vibration when moving. There is a risk of instrument failure.
- Before moving the instrument, read "1.4.1 Precautions for Instrument Installation".

1.4.3 Installing the Instrument

- 1 Remove the fixing tape from the two positions.
- 2 Connect the power cord and AC adapter.
- 3 Insert the power cord into the power input terminal socket on the instrument.
- 4 Plug the AC adapter into an outlet.
- 5 Attach the pipette guide to the pipette guide attachment rails on the instrument.

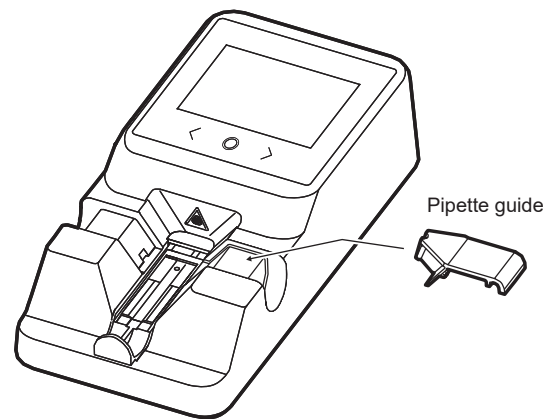

NOTE:

The pipette guide can be attached to either the left side or the right side of the instrument.

1.4.4 Turning on the Power

- 1 Make sure there is no test strip on the strip tray, then insert the strip tray into the instrument.
- 2 Press and hold \odot for 1 second.
Warm-up will complete in about 10 minutes.
- 3 Ensure that the standby screen is displayed.
If the standby screen does not appear and "RE-ADJ?" is displayed, press the \odot button. Automatic adjustment of the optical unit will be performed. You can also press the $[>]$ button to go to the standby screen without performing automatic adjustment. In this case, measurement cannot be performed.

1.4.5 Turning off the Power

- 1 Ensure that the standby screen is displayed.
 - 2 Press and hold \odot for 3 seconds.
- The power will turn off.

Chapter 2 Measurement

2.1 Measurement Precautions

2.1.1 Precautions for Operation



- This instrument is to be operated by qualified persons only. A qualified person is one having adequate knowledge of clinical testing and the disposal of infectious waste. Thoroughly read this operating manual before use.
- Never touch the strip tray or other parts where sample may adhere with your bare hands. During cleaning or maintenance of these parts, wear disposable gloves to prevent exposure to pathogenic microorganisms.
- Dispose of used samples, tips, test strips, parts and instrument in accordance with local regulations for biohazardous waste.



- Ensure the instrument is in a proper environment before turning on the power (see "1.4.1. Precautions for Instrument Installation").
- Do not place containers or bottles that contain liquid on the instrument. Sample or other liquid that gets inside the instrument may cause trouble.
- Never fail to clean or wash the specified components of the instrument to maintain measurement quality (see "Chapter 4. Maintenance").
- If you detect abnormal odors or noise, immediately unplug the AC adapter from the outlet. Continuous operation under these conditions may result in fire or damage to the instrument and consequently lead to personal injury.
- In case of instrument trouble, contact your distributor for repairs. Unauthorized servicing or modification may damage the instrument and consequently lead to personal injury.

2.1.2 Precautions for Samples



- TAKE THE UTMOST CARE WHEN HANDLING BLOOD. This instrument uses blood as sample. Blood may be contaminated with pathogenic microorganisms that can cause infectious diseases. Improper handling of blood may cause infection to the user or other individuals by pathogenic microorganisms.
- Dispose of used samples in accordance with local regulations for biohazardous waste.



- When using a sample that has been stored in a refrigerator or freezer, allow the sample to acclimate to the ambient temperature (10 - 35°C) prior to measurement.
- Do not store a sample in direct sunlight or a location directly exposed to air flow from an air conditioner or other source.

2.1.3 Precautions for Test Strips

REFERENCE:

Purchase of test strips:
Test strips are not included with the instrument. Purchase test strips before using the instrument. For information on purchasing test strips, contact your distributor.

IMPORTANT:

- Use our company's specified dedicated test strips for measurement.
- Carefully read the package insert that comes with the test strips and use test strips before their expiration date.
- Before measurement, remove test strips from refrigeration and allow them to acclimate to room temperature. Measurements using test strips immediately after removing them from refrigeration may lead to inaccurate measurement results.
- Do not use test strips if:
 - they are expired, or
 - the reaction cell is discolored (even before the expiration date).Using test strips of this sort may cause inaccurate measurement results.
- Take out one test strip from its foil pack just before measurement, and set it on the strip tray. If test strip are left out in the open for an extended period of time, they will absorb water from the air or gather dust, which may cause inaccurate measurement results.
- Do not touch test strip reaction cell with your bare hands. Skin oil on the reaction cell may result in inaccurate measurement result. Wear disposable gloves when handling the test strips.
- Do not reuse test strips. Used test strips may cause inaccurate measurement results.

2.1.4 Precautions for Tips

IMPORTANT:

- Do not touch tip end with your bare hands. Contamination on the tip end may lead to inaccurate measurement results.
- Do not reuse the tip. The tip has a water repellent finish that may come off when washed and consequently lead to inaccurate measurement results.

2.2 Sample Measurement

Measure samples using a test strip. Be sure to start with the procedure in "2.2.1 Before Using Test Strips from a New Box".



- Wear disposable gloves to prevent exposure to pathogenic microorganisms.
- If sample adheres to the instrument, wipe it off with a cotton swab or gauze dampened with distilled water. Make sure that no dirt is left, and then ensure that the surface is disinfected with alcohol. Leaving the instrument with the sample adhered to it may cause infection to the user or other individuals by pathogenic microorganisms.
- Dispose of used samples, tips, test strips and disposable gloves in accordance with local regulations for biohazardous waste.



- Be careful not to spill samples.
- Alcohol is very flammable. Keep it away from flames or electrical sparks. Handle with caution. Adequately ventilate the room during use.

2.2.1 Before Using Test Strips from a New Box

Load the reagent information from the IC-CHIP that is included with the reagent. You only need to perform this step once when you start using a test strip from a new box. Before using a test strip from a newly opened box, be sure to load IC-CHIP on the box.

- 1 Insert the IC-CHIP into the IC-CHIP insertion port on the back of the instrument.
- 2 Press and hold the [>] button for 3 seconds.
"READING" appears. After the reagent information is read in from the IC-CHIP, you will return to the standby screen. If reading of the reagent information fails, "NO IC" will appear. Press [>] to exit the display, and then reinsert the IC-CHIP and repeat reading.

2.2.2 Setting the Test Strip

- 1 Tear open the foil pack at the notch.
- 2 Take a test strip out without touching the reaction cell.
- 3 Set the test strip in the groove of the strip tray with the reaction cell facing upward.

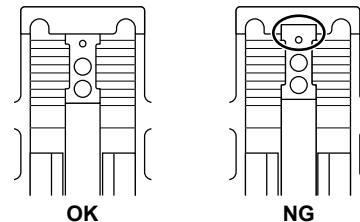

IMPORTANT:

Insert the end of the test strip into the opening at the end of the groove on the strip tray and then fit the entire strip into the groove. If the test strip is warped and/or fails to fit into the groove, it may become jammed inside the instrument or cause inaccurate measurement results.

Chapter 3 Auxiliary Operations

On the menu screen, you can perform instrument settings.

■ To access the menu

On the standby screen, hold down [**<**] for 3 seconds.

■ Options on the menu

● MENU1

Option	MENU No.	Description
1. Date	1 - 1	Sets the date.
2. Time	1 - 2	Sets the time.
3. Date format	1 - 3	Sets the date format. Selectable items: [YMD][MDY][DMY]
4. Sound volume	1 - 4	Sets the beeper volume. Selectable items: 0 to 3

● MENU2

Option	MENU No.	Description
ITEM1 to ITEM16		
Unit	2 - ITEMx	Sets the unit. Selectable items: [] [mmol/L] [μmol/L] [mg/dL] [g/dL] [U/L]
Reference value ON/OFF	2 - ITEMx	Sets the reference value function to [ON] or [OFF].
High reference value	2 - ITEMx	Sets the High reference value.
Low reference value	2 - ITEMx	Sets the Low reference value.
Reagent in IC-CHIP Check parameter reference value	2 - ITEMx	Parameter of reagent in IC-CHIP
User coefficient A	2 - ITEMx	
User coefficient B	2 - ITEMx	

● MENU3

Option	MENU No.	Description	
1. Check measurement	3 - 1	Performs check measurement.	
2. Optical unit	1. Check light intensity	3 - 2 - 1	Checks light intensity of optical unit LED
	2. Light absorbance blank adjustment	3 - 2 - 2	
	3. Light intensity gain adjustment	3 - 2 - 3	Execute this when "E-130" appears.
	4. Barcode threshold setting	3 - 2 - 4	Sets the threshold for scanning test strip barcodes

■ Basic operations in the MENU screen

Change the MENU No. and set values.

[**<**] button: Moves the position of the selected digit (the digit that is blinking) back one space.

[**⊙**] button: Finalizes the value that is being set (the value that is blinking), and move the position of the selected digit forward one space.

[**>**] button: Increases the value of the blinking digit by one. When the upper limit of the setting range is reached, the value returns to the beginning value.

(Example: When the setting range is 0 to 9
0⇒1⇒2⇒...⇒8⇒9⇒0)

■ Selecting a MENU item

Enter a MENU No. indicated in the above table to set that item or execute that function.

The following shows an example of how the date and time are set.

① On the standby screen, press and hold [**<**] for 3 seconds to display the MENU screen.

"1-0-0" will appear in the sub-screen with the "1" (digit) blinking.

② Press the [**⊙**] button.

The "1" will stop blinking and the middle "0" digit will change to "1" and start blinking.

③ Press the [**>**] button once.

The middle digit will change to "2".

④ Press the [**⊙**] button.

The MENU No. will be finalized as "1-2" and the screen will transition to the time setting screen.

⑤ Set the tens digit and the ones digit for the hour, and then set the tens digit and the ones digit for the minute, in that order.

* Repeat the same steps as above to select and set the values of the other MENU items.

2.2.3 Measuring the Sample

- 1 Firmly and securely attach the pipette tip to the end of the pipette.
- 2 Aspirate the sample with the pipette.
- 3 Press the [**⊙**] button, and then dispense a drop of sample on the test strip. Dispense the sample onto the sample dispense area of the test strip. Press the pipette button all the way in slowly.
- 4 After you dispense a drop of sample, immediately press the [**⊙**] button and insert the strip tray into the instrument. (Insert the strip tray within 10 seconds of pressing the [**⊙**] button in step ④.)
- 5 After the measurement time elapses, the measurement results appear on the display.
- 6 Check the measurement results.
- 7 Withdraw the strip tray and take out the used test strip. Check the test strip, and check that the sample has flowed in correctly and that there are no large air bubbles or foreign matter in the reaction cell. After checking, discard the test strip.
- 8 The standby screen will appear 5 seconds after withdrawing the strip tray.

2.2.4 Measuring the control

- 1 On the standby screen, press the [**>**] button. The control icon will appear.
- 2 Dispense a drop of the control onto the test strip, and then perform the same procedure as when measuring a sample.
- 3 The measurement results are saved as a control measurement.

2.2.5 Understanding results

After measurement, the following information appears on the screen.

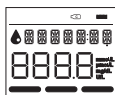

Upper line: The item name and measurement number appear alternately.

If you press the [**⊙**] button, the display changes to the date and time.

If there is a status indication (*), the status appears instead of the measurement number.

Lower line: The measurement result value and units appear. However, if the status is UNDER or OVER, the measurement range appears.

(*) Status

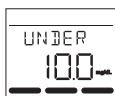

UNDER Under the lower limit of the measurement range.

Check the conditions. It is possible that drop dispensing failed and the sample did not enter the reaction cell, or a large bubble formed.



OVER Over the upper limit of the measurement range.



OVER* Over the upper limit of the measurement range, and the prozone effect or a reaction abnormality may have occurred.



HIGH The value is higher than the reference value. (only when a reference value is set)



LOW The value is lower than the reference value. (only when a reference value is set)

2.2.6 Checking the measurement result history

- 1 On the standby screen, press [**<**].
The current date and time screen appears.
- 2 Press [**>**].
The most recent test results appear.
Pressing [**>**] again displays the measurement results prior to the one currently displayed.

Chapter 4 Maintenance

This section lists the parts that require maintenance and the standard frequency to perform maintenance tasks. Referring to the below, clean or replace the parts at recommended intervals.



- Wear disposable gloves to prevent exposure to pathogenic microorganisms when performing maintenance tasks marked with a biohazard icon.
- Dispose of used consumables and cleaning tools in accordance with local regulations for biohazardous waste.



Alcohol is used for some maintenance of the instrument. Alcohol is very flammable. Keep it away from flames or electrical sparks. Handle it with caution. Adequately ventilate the room during use.

1 Clean the strip tray <At the end of the day>

When measurement for the day is complete, be sure to clean the strip tray.

Prepare: cotton swabs, distilled water, soft cloth, alcohol and disposable gloves

Use a soft cloth or cotton swab moistened with water or alcohol to clean the strip tray.

2 Cleaning the photometric window (when “E-130” occurs)

Prepare: cleaning pad, distilled water, alcohol and disposable gloves

Clean the photometric window as explained in the leaflet for the cleaning pad.

Chapter 5 Troubleshooting

When a problem occurs in the instrument, an error code will be displayed as shown below.

If an error code is displayed, refer to the table below to take appropriate action. If this does not solve the problem and you were using a mobile battery, connect the AC adapter and check operation. If you were using the AC adapter from the beginning or if the problem still occurs after connecting the AC adapter, contact your distributor.

5.1 If a Warning Occurs

5.1.1 From Warning Occurrence to Remedy

The instrument notifies you of a warning by:

- Emitting short beeps.
- Displaying a warning code and message.

If a warning occurs, take the necessary actions to remove the cause (see “5.1.2. Causes and Remedies”). If the warning persists, turn off the power and contact your distributor.

5.1.2 Causes and Remedies

No.	Cause	Remedy
NO IC	IC-CHIP is not inserted.	Insert the IC-CHIP inside of the box of the test strip to be measured into the IC-CHIP insertion port.
PCS	QC measurement has not been performed, or the expiration date of the QC measurement has passed.	Perform QC measurement.
TRAY OUT	The strip tray is not inserted.	Insert the strip tray. (The warning will be automatically cleared.)
TRAY IN	The strip tray is still inserted.	Remove the strip tray. (The warning will be automatically cleared.)
T OVER	The strip tray was not inserted within 10 seconds of pressing the button.	Press the button and repeat measurement from the beginning.
RGNT IN	A test strip is still in the strip tray.	Withdraw the strip tray, discard the test strip, and insert the strip tray again.

5.2 If an Error Occurs





5.2.1 From Error Occurrence to Remedy

The instrument notifies you of an error by:

- Emitting short beeps.
- Displaying an error code and message.

If an error occurs, take the necessary actions to remove the cause (see "5.2.2. Causes and Remedies"). If the error persists, turn off the power and contact your distributor.

5.2.2 Causes and Remedies

No.	Cause	Remedy
E-102	A problem occurred in communication with an external device.	Connect the external device with the communication cable correctly.
E-103	The date and time settings are incorrect.	Set the date and time correctly.
E-122	The photometric window is dirty.	Clean the photometric window.
E-123	The ambient temperature of the instrument is less than 10°C or over 35°C.	Adjust ambient temperature so as to create a suitable environment for measurement (10 - 35°C).
E-124	The test strip has expired.	Use a new test strip and repeat measurement.
E-126	The tray was withdrawn during measurement.	Press the  button to clear the error, and repeat measurement.
E-128	The measurement count limit of the inserted IC-CHIP has been exceeded.	Insert the IC-CHIP inside of the box of the test strip to be measured into the port on the back of the instrument, and repeat measurement.
E-129	Unable to read the test strip barcode.	Press the  button to clear the error, and repeat measurement.
E-130	The photometric window is dirty.	Press the  button to clear the error, and use a cleaning pad to clean the photometric window. The cleaning method is indicated in the leaflet that is included with the cleaning pad.
E-131	The measurement unit's light intensity is abnormal.	Adjust the light intensity gain.
E-132	A different IC-CHIP is inserted.	Press the  button to clear the error, insert the IC-CHIP inside of the box of the test strip to be measured into the dedicated port on the back of the instrument, and repeat measurement.

5.3 If Trouble Occurs

5.3.1 From Trouble Occurrence to Remedy

The instrument alerts you of a trouble by:

- Emitting short beeps.
- Displaying a trouble code.

If same as above occurs, take the necessary actions to remove the cause (see "5.3.2. Causes and Remedies"). If the trouble persists, turn off the power and contact your distributor.

5.3.2 Causes and Remedies

No.	Cause	Remedy
T-201	A malfunction occurred with the optical unit.	Turn off the power and contact your distributor.
T-221	A malfunction occurred with the internal temperature control.	Adjust ambient temperature so as to create a suitable environment for measurement (10 - 35°C).
T-222	An internal malfunction occurred.	Turn off the power and contact your distributor.
T-223	A malfunction occurred with the optical unit.	Clean the transmission photometric holes or photometric window. If a used test strip is still in the strip tray, remove it.
T-999	An internal malfunction occurred.	Turn off the power and contact your distributor.