

CHUWA^{AP 無煙焼却炉}STAR[®]

Simple
Compact
Solidity
Smokeless

MODEL F

CHUWA^{AP 無煙焼却炉}STAR[®]'s advantages

- Smokeless incineration
- Various wastes can be incinerated together
- Quick incineration
- Excellent durability
- Air conditioning system by heat recycling system

CHUWA^{AP 無煙焼却炉}STAR[®]'s equipment

- Second furnace, heat proof up to 1100°C
- Ignition & After burner
- Thermostat & thermometer
- Cyclone dust collector
- Ejector
- Water cooled pipe against backfire
- Water level control & alert system

CHUWA^{AP 無煙焼却炉}STAR[®] can dispose of

- Dialyzer, Catheter, Blood bag, Urine bag, Syringe, Ringer bottle, Spitz, Laboratory dish, Glove, Disposal diapers, Gauze, Absorbent cotton, etc.
- Polyethylene, polypropylene, polystyrene, Foamed polystyrene, Vinyl acetate, Polyester, Acrylic, Epoxy, Phenol, Melamine, FRP, ABS, Nylon, Film, etc.
- Natural rubber, Synthetic rubber, Artificial leather, Ebonite, Tire, etc.
- Waste oil, waste solvent, waste paint, Waste cloth, etc.
- Paper, cardboard, wood, fiber, general rubbish, etc.



MODEL F

AP 無煙焼却炉
CHUWA STAR®

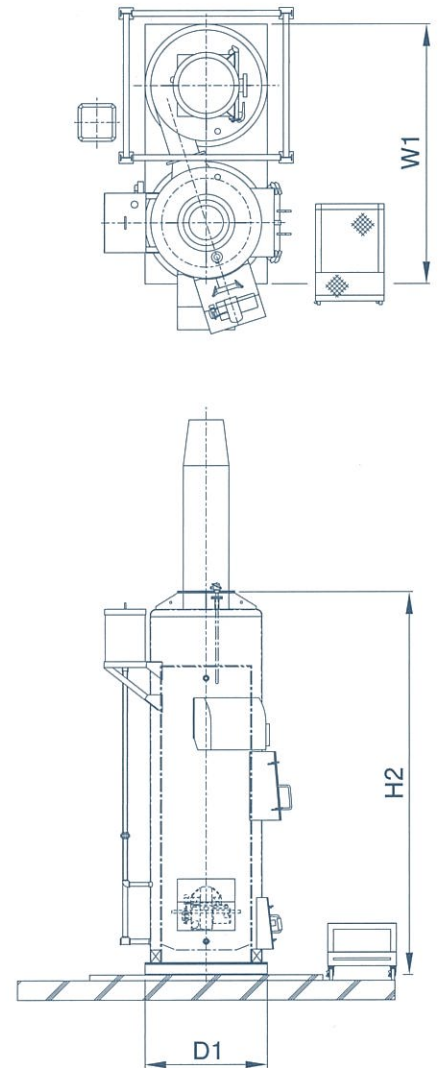
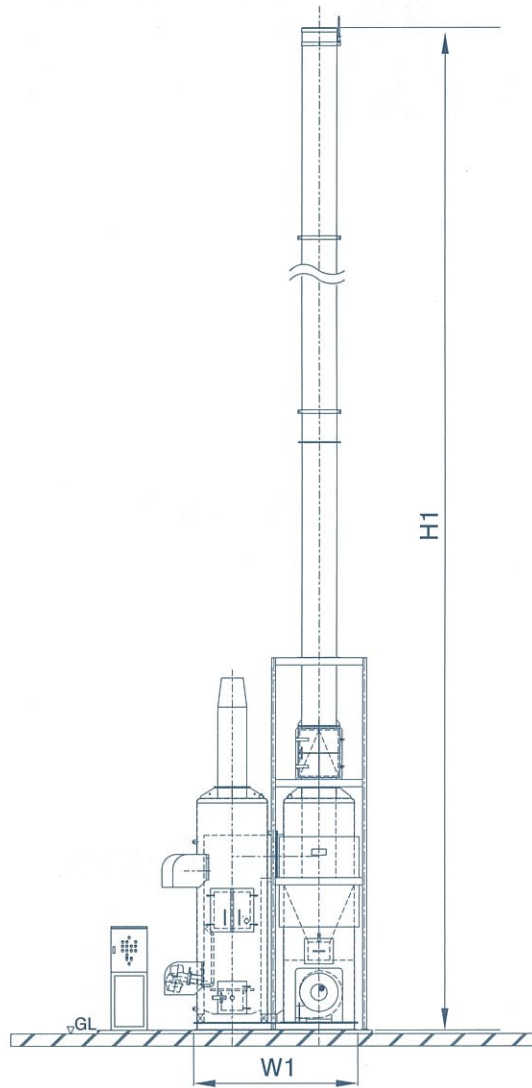

Size

Model		FE-15KHH	F-ISKHH	F-1KHH	F-1IKHH
Total height	H1	20,000	20,000	20,000	20,000
Incinerator height	H2	1,925	2,280	2,725	3,350
Waste inlet	□	450□	450□	500□	500□
Floor space	A×B	1,850×870	1,810×880	1,840×910	2,270×1,070

Standard Specification

Model		FE-15KHH	F-ISKHH	F-1KHH	F-1IKHH
Capacity	kg/day	120~160	160~200	200~300	400~600
Hearth	m ²	0.26	0.26	0.36	0.48
Furnace capacity	m ³	0.24	0.24	0.40	0.60
Net weight	kg	980	1,330	1,570	2,460
Working weight	kg	1,360	1,730	2,070	3,160

Standard Specification

Model			FE-15KHH	F-ISKHH	F-1KHH	F-1IKHH
Blower	Power	kw	0.75	0.75	1.5	2.2
	Air Press	kPa	2.5	2.51	2.8	3.2
	Air Vol	m ³ /min	20	20	26	40
Ignition burner	Power	kw	0.02	0.02	0.15	0.15
	Oil	ℓ/hr	5.7	5.7	9.5	9.5
	Control	control	ON-OFF	ON-OFF	ON-OFF	ON-OFF
Second burner	Power	kw	0.02	0.02	0.15	0.25
	Oil	ℓ/hr	7.6	7.6	9.5	15.1
	Control	control	ON-OFF	ON-OFF	ON-OFF	ON-OFF
Vapor		ℓ/hr	70	80	100	160
Water		ℓ/hr	380	400	500	700

※ The specifications are changed without any notice for product improvement.

Agent

CHUWA INDUSTRIAL CO.,LTD.

■ Head Office Zip 104-0032
15-1, Hatchobori 2chome Chuo-ku Tokyo, Japan
TEL:+ 81-3-6410-5211 FAX:+ 81-3-6410-5212
E-mail chuwa-kikou@chuwastar.co.jp
HP <http://www.chuwastar.co.jp>

■ Branch Osaka / Nagoya / Fukuoka / Kofu