

Horizontal model

AP 無煙焼却炉
CHUWASTAR[®]

Safty Sterillization!
Speedy Volumedown!
Superior Combustibleness!

CX TYPE

CHUWASTAR's advantages

- Smokeless incineration
- High temperature combustion
- Quick incineration
- Various wastes can be incinerated together
- Excellent durability
- Heat recycling system, Utilization of hot water

CHUWASTAR's standard equipment

- Second furnace, heat proof up to 1,100°C
- Ignition & After burner
- Gas treatment device
- Cyclone dust collector
- Water level control & alert system

CHUWASTAR's structure

- Fixed floor combustion method
- Water-jacket cooled structure
- A forced air supply method

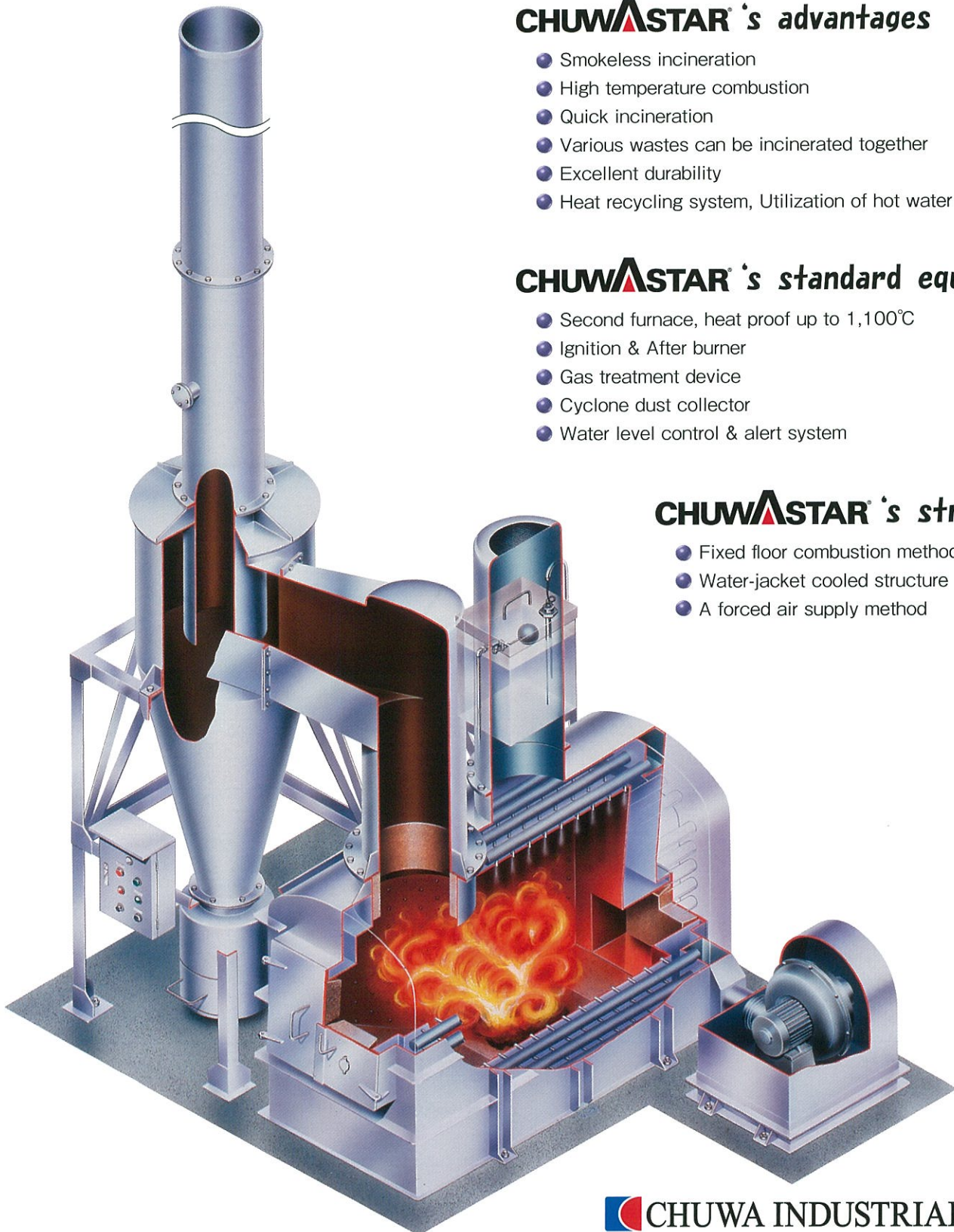

 **CHUWA INDUSTRIAL CO.,LTD.**

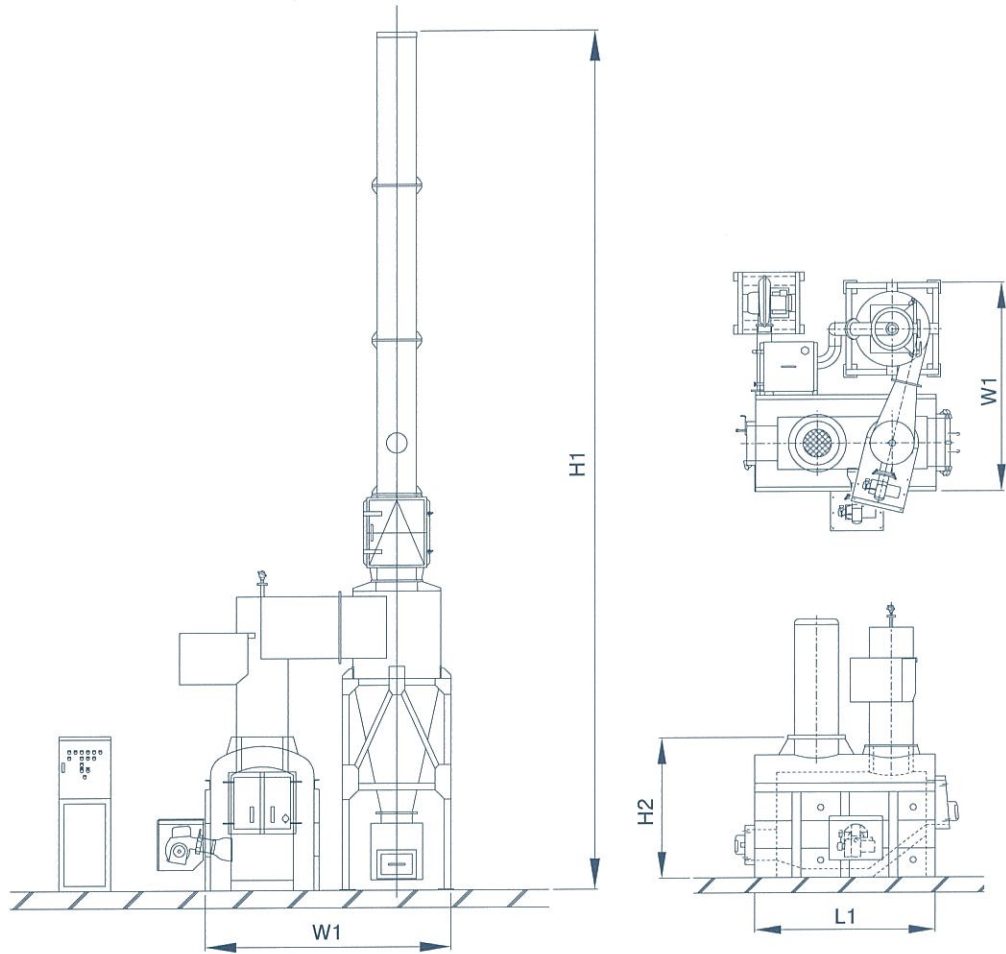

● Size

Model	Sign	CX-1K	CX-2K	CX-3K	CX-4K	CX-5K
Total Height	H1	8340	8780	9150	9700	10200
Incinerator Height	H2	1600	1800	1900	2000	2100
Incinerator Length	L	2050	2350	2500	2650	2800
Incinerator Width	W1	2375	2575	2750	2975	3200
Waste Inlet	□	550 × 500	600 × 500	650 × 550	700 × 600	800 × 650

● Standard Specification

Model	Sign	CX-1K	CX-2K	CX-3K	CX-4K	CX-5K
Capacity	kg/day	400 ~ 470	600 ~ 680	800 ~ 950	1000 ~ 1300	1200 ~ 1500
Hearth	m ²	1.02	1.40	1.72	2.07	2.45
Furnace Capacity	m ³	1.12	1.75	2.58	3.26	4.04
Electro Souce	V	200	200	200	200	200
Blower Power	kW	2.2	3.7	5.5	7.5	11
Blower Air Pressure	Pa	3000	4500	5300	5800	8200
Blower Air Volume	m ³ /min	42	45	65	70	75
Blower Revolution	rpm	2890	2930	2935	2940	2950
Vapor Water Quantity	ℓ/h	145	220	290	360	400
Net Weight	kg	2160	3000	4200	5760	7100
Water Weight	kg	1330	1800	2300	3400	3900
Working Weight	kg	3490	4800	6500	9160	11000

※ The specifications are changed without any notice for product improvement.

※ The processing capacity differs by a processing thing.

■ AGENT

■ CHUWA INDUSTRIAL CO.,LTD.

■ Head Office Zip 103-0023
8-7, Nihonbashi-honcho 2-chome, Chuo-ku,
Tokyo, Japan
TEL: +81-3-5643-2571 FAX: +81-3-5643-2572
E-mail: chuwa-kikou@chuwastar.co.jp
URL: <http://www.chuwastar.co.jp>

■ Branch Osaka / Nagoya / Fukuoka / Kofu